



SAFEWAZE

Post Anchor Manual



FS-EX325



FS-EX326

STANDARDS	
OSHA	1926.502, 1910.140, 1910.66

**Read and understand instructions before using equipment!
Do not throw away instructions!**

**Always verify the latest revision of the Safewaze Manual is being utilized.
Visit the Safewaze website, or contact Customer Service, for updated manuals.**

⚠️ IMPORTANT:

- Please refer to this manual for essential instructions on the use, care, or suitability of this equipment for your application. Contact Safewaze for any additional questions.
- Record all important product information prior to use. Documentation of all Competent Person annual inspections is required in the Inspection Log.

▶ USER INFORMATION

Date of First Use: _____

Serial Number: _____

Trainer: _____

User: _____

▶ SAFETY INFORMATION AND PRECAUTIONS

- The manufacturer's instructions must be provided to users of this equipment.
- The user must read, understand, and follow all safety and usage information contained within this manual.
- The user must safely and effectively use the Post Anchor and all equipment used in conjunction with the anchor.
- Failure to follow all safety and usage information can result in serious injury or death.

⚠Warnings:

Regulations included herein are not all-inclusive, are for reference only, and are not intended to replace a Competent Person's judgment or knowledge of federal or state standards.

The warnings indicated below are designed to minimize risk associated with the use of a Safewaze harness.

- Users shall consult with their doctor to verify ability to safely absorb the forces of a fall arrest event. Fitness level, age, and other health conditions can greatly affect an individual's ability to withstand fall arrest forces. Women who are pregnant and individuals considered minors must not use any Safewaze equipment.
- Do not alter or misuse equipment. Only Safewaze, or entities authorized in writing by Safewaze, may make repairs to Safewaze fall protection equipment.
- A Competent Person must conduct an analysis of the workplace and anticipate where workers will be conducting their duties, the route they will take to reach their work, and any existing and potential fall hazards. The Competent Person must choose the fall protection equipment to be utilized. Selections must account for all potential hazardous workplace conditions. All fall protection equipment shall be purchased in new and unused condition.
- Training of Authorized Persons to correctly install, inspect, disassemble, maintain, store, and use equipment must be provided by a Competent Person. Training must include the ability to recognize fall hazards, minimize the likelihood of fall hazards, and the correct use of personal fall arrest systems.
- Equipment that is exposed to fall arrest forces must be immediately removed from service and destroyed.
- Equipment designated for fall protection must never be used to lift, hang, support, or hoist tools or equipment unless specifically certified for such use.
- Use of a body belt is not authorized for fall arrest applications.
- Work directly under the anchor point as much as possible to minimize swing fall hazards.
- The user must ensure that there is adequate fall clearance when working at height.
- Avoid using the product in applications where engulfment hazards exist.
- If work is conducted in a high heat environment, ensure that Arc Flash or other suitable fall protection equipment is utilized.
- Avoid moving machinery, sharp and/or abrasive edges, and any other hazard that could damage or degrade the component.
- Utilize extra caution to keep lifeline free from any obstructions including, but not limited to, surrounding objects, tools, equipment, moving machinery, co-workers, yourself, or possible impact from overhead objects.

TABLE OF CONTENTS

1.0 ▶ Introduction	5
2.0 ▶ Intended Use	5
3.0 ▶ Applicable Safety Standards	5
4.0 ▶ Worker Classifications	5
5.0 ▶ Rescue Plan	6
6.0 ▶ Product Limitations	6
7.0 ▶ Allowed Anchorage Applications	7
8.0 ▶ Product Specifications	8
9.0 ▶ Fall Clearance	8
10.0 ▶ Compatibility of Connectors	11
11.0 ▶ Making Connections	12
12.0 ▶ Positioning of Post Anchor	12
13.0 ▶ Installation of Anchor (Engineered Wood)	14
14.0 ▶ Installation of Anchor (Existing Wood)	15
15.0 ▶ Installation of Anchor (Concrete)	18
16.0 ▶ Installation of Anchor (Steel)	19
17.0 ▶ Inspection & Maintenance	20
18.0 ▶ Label	21
19.0 ▶ Anchor Inspection Form	22
20.0 ▶ Annual Inspection Form	23

► 1.0 INTRODUCTION

Thank you for purchasing a Safewaze Post Anchor. The anchor is intended for use as part of a complete Personal Fall Arrest, Restraint, Work Positioning, or Rescue System. The Post Anchor is a fixed, permanent anchor designed for installation on wood, steel, and concrete. The anchor is equipped with a connection point that can be used as a single anchor point for fall protection equipment or with a Horizontal Lifeline (HLL) system.

Safewaze anchors are designed for a single user whose weight (including clothing, tools, equipment, etc.) is:

ANSI 130-310 lbs. (58.96-140.61 kg)
OSHA Up to 420 lbs. (190.51 kg)

This manual must be read and understood in its entirety and used as part of an employee training program as required by OSHA or any applicable state agency.

► 2.0 INTENDED USE

The equipment covered in this manual is intended for use as part of a complete personal fall protection system. Use of this equipment for any other purpose including, but not limited to, sports or recreational activities, non-approved material handling applications, or other action not described in these instructions, is not approved by Safewaze. Use of this equipment in a manner outside the scope of those covered within this manual can result in serious injury or death. The equipment covered in this manual must only be used by trained personnel in workplace applications. If the anchor is used for training, a secondary fall protection system must be used so the trainee is not exposed to accidental fall hazards.

► 3.0 APPLICABLE SAFETY STANDARDS

When used according to instructions, this product meets **OSHA 1926.502, 1910.140, and 1910.66** regulations. Applicable standards and regulations depend on the type of work being done and may include state-specific regulations. Refer to local, state, and federal requirements for additional information on the governing of occupational safety regarding Personal Fall Arrest Systems (PFAS).

► 4.0 WORKER CLASSIFICATIONS

Read and understand the definitions of those who work in proximity of, or may be exposed to, fall hazards:

Qualified Engineer: A person with a Bachelor of Science in Engineering degree from an accredited college or university. They are able to assume personal responsibility for the development and application of engineering science and knowledge in the design, construction, use, and maintenance of their projects.

Qualified Person: One who, by possession of a recognized degree, certificate, or professional standing, or who by extensive knowledge, training, and experience, has successfully demonstrated their ability to solve or resolve problems relating to the subject matter, the work, or the project.

Competent Person: One who is capable of identifying existing and predictable hazards in the surroundings or working conditions which are unsanitary, hazardous, or dangerous to employees, and who has authorization to take prompt corrective measures to eliminate them.

Authorized Person: A person approved or assigned by the employer to perform a specific type of duty or duties, or to be at a specific location or locations, at the jobsite.

It is the responsibility of a Qualified Person or Engineer to supervise the jobsite and ensure safety regulations are met.

► 5.0 RESCUE PLAN

Prior to the use of this equipment, employers must create a rescue plan in the event of a fall and provide the means to implement the plan through training. The rescue plan must be specific to the project. The rescue plan must allow for employees to rescue themselves or be promptly rescued by alternative means.

This plan must be communicated to/understood by all equipment users, authorized persons, and rescuers. Rescue operations may require specialized equipment beyond the scope of this manual. Every user must be trained in the inspection, installation, operation, and proper usage of their Rescue Equipment and Rescue Plan. See ANSI Z359.4-2013 for specific rescue information. Immediately seek medical attention in the event a worker suffers a fall arrest incident.

Note: Special rescue measures may be required for a fall over an edge.

► 6.0 PRODUCT LIMITATIONS

When installing or using this equipment always refer to the following requirements and limitations:

- **Capacity Range:** ANSI 130-310 lbs. (59-141 kg), OSHA up to 420 lbs.
- **Anchorage:** Anchorages selected for fall arrest systems shall have a strength capable of sustaining static loads applied in the directions permitted by the system of at least:
 1. 5,000 lbs. (2267.9 kg) for non-certified anchorages, or
 2. Two times the maximum arresting force for certified anchorages.

When more than one fall arrest system is attached to an anchorage, the strengths set forth in one of the above shall be multiplied by the number of systems attached to the anchorage.

From OSHA 1926.502 and 1910.66: Anchorages used for attachment of personal fall arrest systems shall be independent of any anchorage being used to support or suspend platforms and capable of supporting at least 5,000 lbs. (2267.9 kg) per user attached. Or, anchorages for attachment shall be designed, installed, and used as part of a complete PFAS which maintains a safety factor of at least two and is under the supervision of a Qualified Person.

- **Locking Speed:** The nature of an SRL requires a clear fall path to ensure the SRL will lock in the event of a fall. Working in obstructed fall paths, cramped areas, or on moving materials like sand and grain, may not allow the user's body to gain enough speed buildup to cause the SRL to engage and lock in the event of a fall.
- **Free Fall:** The distance a user falls before the fall arrester activates.
- **Swing Falls:** As the user moves laterally away from an overhead anchor point, the risks related to swing falls increase. The force of striking an object involving swing fall can in some instances generate more forces than a fall with the user wearing no fall protection equipment. Minimize swing falls by working as directly below the anchorage point as possible.
- **Fall Clearance:** Fall Clearance (FC) is the total combined values of the Rope Elongation, Lanyard Length, Deceleration Distance, Harness Stretch, Height of Worker, and Safety Factor. Safewaze uses a 2 ft. Safety Factor. The Safety Factor includes fall arrester slippage. Refer to the chosen PFAS system's product manual when calculating fall clearance.

Additional Fall Clearance is required for falls from a kneeling or crouched position. If a Swing Fall hazard exists, the total vertical fall distance will be greater than if the user had fallen directly under the anchor point. This manual provides information regarding Swing Fall hazards and additional Fall Clearance Requirements in Section 9.

- **Hazards:** Extra precautions shall be taken if this equipment is used in an environment where hazards exist. Hazards can include, but are not limited to, moving machinery, high voltage equipment or power lines, caustic chemicals, corrosive environments, toxic or explosive gases, or high heat. Avoid working in an area where overhead equipment or personnel could fall and contact the user, fall protection equipment, or the lifeline. Areas where the user's lifeline may cross or tangle with the lifeline of another user shall be avoided. Do not allow the lifeline to pass under arms or between the legs.
- **Sharp Edges:** Safewaze **Class 1 SRLs** are NOT designed for use in Leading Edge Environments. If a specific work area has a sharp edge/edges that may come into contact with the lifeline constituent of the SRL, a Class 2 SRL is required.

▶ 7.0 ALLOWED ANCHORAGE APPLICATIONS

Personal Fall Arrest: Safewaze Anchors are designed as an anchor point to support a maximum of 1 PFAS when utilized for fall protection applications. The structure to which the anchor is attached must withstand loads applied in the directions permitted by the system of at least 5,000 lbs. (22 kN) or be designed with a safety factor of two to one. Maximum allowable free fall is based on the connector used.



Restraint: Safewaze Anchors are authorized for use in Restraint applications. The structure to which the anchor is attached must withstand loads applied in the directions permitted by the system of at least 1,000 lbs. NO free fall is permitted. Restraint systems may only be used on surfaces with slopes up to 4/12 (vertical/horizontal). For Restraint applications, the allowable attachment points to the harness are Dorsal, Front/Sternal, Side, and Shoulder D-rings.



Work Positioning: Safewaze Anchors are authorized for use in Work Positioning applications. Work Positioning allows a worker to be supported during suspension while freeing both hands to conduct work operations. The structure to which the Anchor is attached must withstand loads applied in the directions permitted by the system of at least 3,000 lbs. Maximum allowable free fall is 2 ft. For positioning applications, the allowable attachment points to the harness are the Side D-rings.



Rescue/Confined Space: Safewaze Anchors are authorized for use in Rescue/Confined Space applications. Rescue systems are utilized to safely recover a worker from a confined location or after exposure to a fall. Composition of rescue systems can vary based upon the type of rescue involved. The structure to which the anchor is attached must withstand loads applied in the directions permitted by the system of at least 3,100 lbs. NO free fall is permitted for rescue scenarios. For confined space scenarios, maximum allowable free fall is based on the PFAS used. For these applications, the allowable attachment points to the harness are Dorsal, Front/Sternal, and Shoulder D-rings.



► 8.0 PRODUCT SPECIFICATIONS

- FS-EX325: 12" Post, 31.3 lbs. (14.2 kg)
- FS-EX326: 18" Post, 36.0 lbs. (16.3 kg)
- For use on wood, steel, and concrete.
- Minimum Breaking Strength (MBS): 5,000 lbs. (22.24 kN)
- Suitable for HLL use. Must be installed at least 2 ft. away from another anchor.
- Fall Arrest Points: 1 galvanized steel connection point.
- Baseplate: 16" x 16"
- Material: Galvanized Steel.
- Fasteners not included.

► 9.0 FALL CLEARANCE

Always select an SRL/lanyard and anchor point location that limits free fall and swing fall as much as possible. Refer to the chosen PFAS system manuals for information on fall clearance. A free fall of more than 6 ft. could cause excessive arrest forces that could result in serious injury or death.

- **Fall Clearance:** There must be sufficient clearance below the anchorage connector to arrest a fall before the user strikes the ground or an obstruction. When calculating fall clearance, account for all applicable factors. A Competent Person must reference the entire system's components to calculate Fall Clearance.

THE FOLLOWING DIAGRAMS ARE EXAMPLES ONLY.

Note: Numbers used in these examples are based on ZERO offset and setback with the anchor directly overhead or below, to represent an in-line Fall Clearance calculation. Consult with a Competent Person when working in different scenarios and when using non-Safewaze equipment.

6' FREE FALL LANYARD (OVERHEAD) EXAMPLE

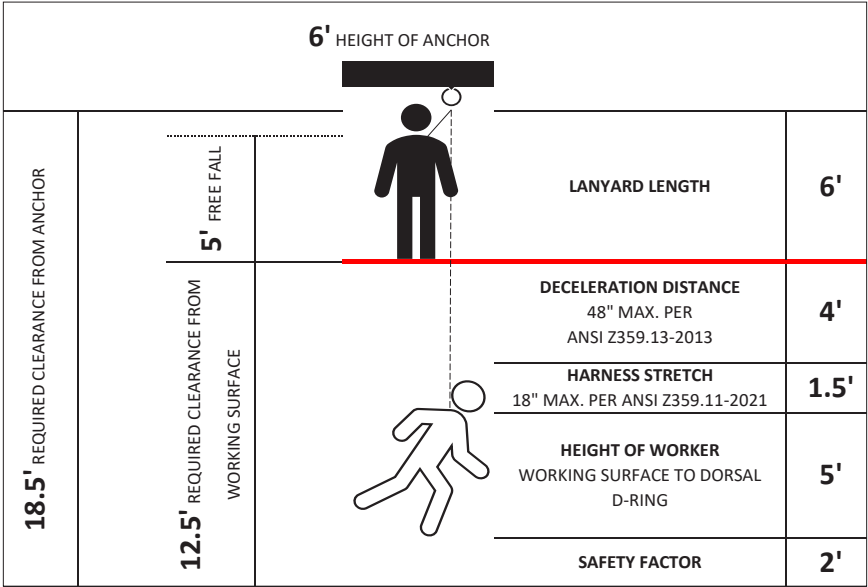

12' FREE FALL LANYARD (BELOW D-RING) EXAMPLE

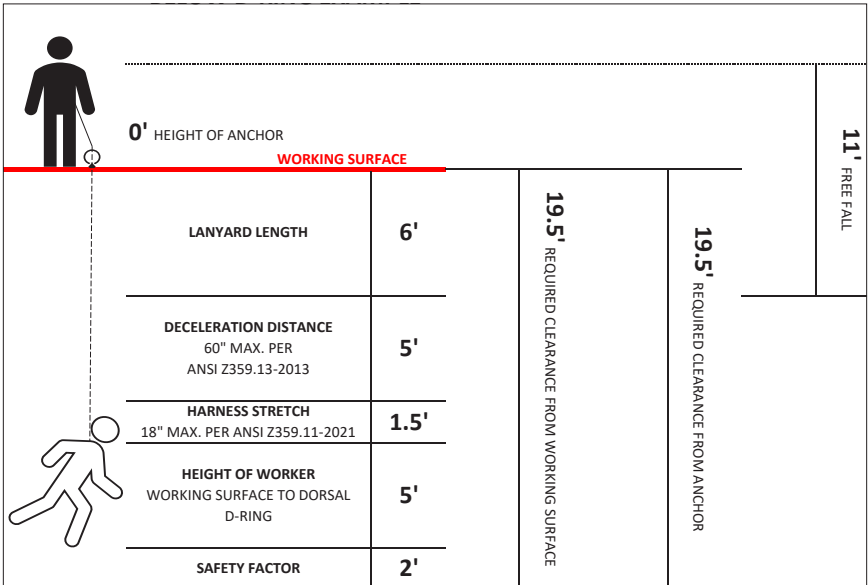

CLASS 1 (OVERHEAD) EXAMPLE

<p>6' HEIGHT OF ANCHOR</p>		<p>0' FREE FALL</p>	
		<p>7' REQUIRED CLEARANCE FROM WORKING SURFACE</p>	
<p>13' REQUIRED CLEARANCE FROM ANCHOR</p>		<p>ARREST DISTANCE 42" MAX. PER ANSI Z359.14-2021 CLASS 1</p>	<p>3.5'</p>
		<p>HARNES STRETCH 18" MAX. PER ANSI Z359.11-2021</p>	<p>1.5'</p>
		<p>SAFETY FACTOR</p>	<p>2'</p>
		<p>SWING FALL DROP DISTANCE</p>	

CLASS 2 (BELOW D-RING) EXAMPLE

<p>0' HEIGHT OF ANCHOR</p>	<p>5' FREE FALL</p>	
	<p>16.5' REQUIRED CLEARANCE FROM WORKING SURFACE</p>	
	<p>ARREST DISTANCE REFER TO MANUAL FOR PUBLISHED ARREST DISTANCES PER ANSI Z359.14-2021 CLASS 2</p>	<p>8'</p>
	<p>HARNES STRETCH 18" MAX. PER ANSI Z359.11-2021</p>	<p>1.5'</p>
	<p>HEIGHT OF WORKER WORKING SURFACE TO DORSAL D-RING</p>	<p>5'</p>
	<p>SAFETY FACTOR</p>	<p>2'</p>
	<p>SWING FALL DROP DISTANCE</p>	
		<p>16.5' REQUIRED CLEARANCE FROM ANCHOR</p>

- **Swing Falls:** Prior to installation or use, make considerations for eliminating or minimizing all swing fall hazards. Swing falls occur when the anchor is not directly above the location where a fall occurs. Always work as close to, or in line with, the anchor point as possible. Swing falls significantly increase the likelihood of serious injury or death in the event of a fall (Figure 1). Ensure a Competent Person includes swing fall in calculations if the hazard exists.

FIGURE 1: SWING FALL

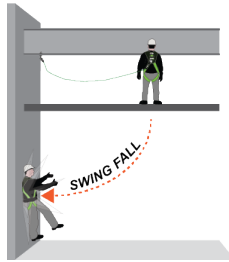

► 10.0 COMPATIBILITY OF CONNECTORS

- Safewaze equipment is designed for, and tested with, associated Safewaze components or systems. If substitutions or replacements are made, ensure all components meet the applicable ANSI requirements. Read and follow manufacturer's instructions for all components and subsystems in your PFAS. Not following this guidance may jeopardize compatibility of equipment and possibly affect the safety and reliability of the system.
- Connectors are compatible with connecting elements when they have been designed to work together in such a way that their sizes and shapes do not cause their gate mechanisms to inadvertently open regardless of how they become oriented.
- Connectors (hooks, carabiners, and D-rings) must be capable of supporting at least 5,000 lbs. (22 kN).
- Connectors must be compatible with the anchorage or other system components.
- Do not use equipment that is not compatible. Non-compatible connectors may unintentionally disengage (Figure 2).
- Connectors must be compatible in size, shape, and strength.
- Self-locking snap hooks and carabiners are required by OSHA guidelines.
- Some specialty connectors have additional requirements. Contact Safewaze if you have any questions about compatibility.

FIGURE 2: UNINTENTIONAL DISENGAGEMENT

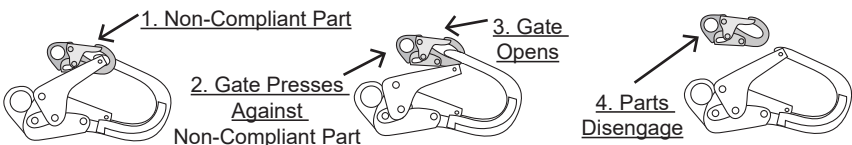

Using a connector that is undersized or irregular in shape (1) to connect a snap hook or carabiner could allow the connector to force open the gate of the snap hook or carabiner. When force is applied, the gate of the hook or carabiner presses against the non-compliant part (2) and forces open the gate (3). This allows the snap hook or carabiner to disengage (4) from the connection point.

► 11.0 MAKING CONNECTIONS

Snap hooks and carabiners used with this equipment must be double locking and/ or twist lock. Ensure all connections are compatible in size, shape, and strength. Do not use equipment that is not compatible. Ensure all connectors are fully closed and locked.

Safewaze connectors (hooks, carabiners, and D-rings) are designed to be used only as specified in each product's manual. See Figure 3 for examples of inappropriate connections. Do not connect snap hooks and carabiners:

- To a D-ring to which another connector is attached.
- In a manner that would result in a load on the gate (with the exception of tie-back hooks).
- In a false engagement, where features that protrude from the snap hook or carabiner catch on the anchor, and without visual confirmation seems to be fully engaged to the anchor point.
- To each other.
- By wrapping the web lifeline around an anchor and securing to lifeline, except as allowed for tie-back models.
- To any object which is shaped or sized in a way that the snap hook or carabiner will not close and lock, or that roll-out could occur.
- In a manner that does not allow the connector to align properly while under load.

FIGURE 3: INAPPROPRIATE CONNECTIONS

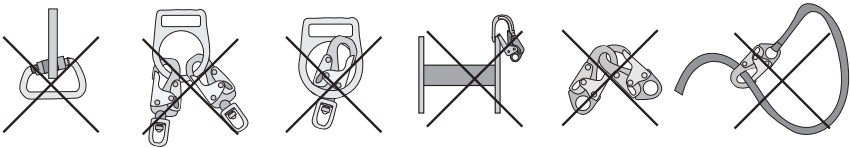

Large throat snap hooks must not be connected to standard size D-rings or similar objects which will result in a load on the gate if the hook or D-ring twists or rotates, unless the snap hook complies with ANSI Z359.1-2007 or ANSI Z359.12 and is equipped with a 3,600 lb. (16 kN) gate.

► 12.0 POSITIONING OF THE POST ANCHOR AT THE INTENDED INSTALLATION LOCATION

Prior to the installation of the anchor, review page 13 for information and requirements on positioning the Post Anchor at the intended installation location.

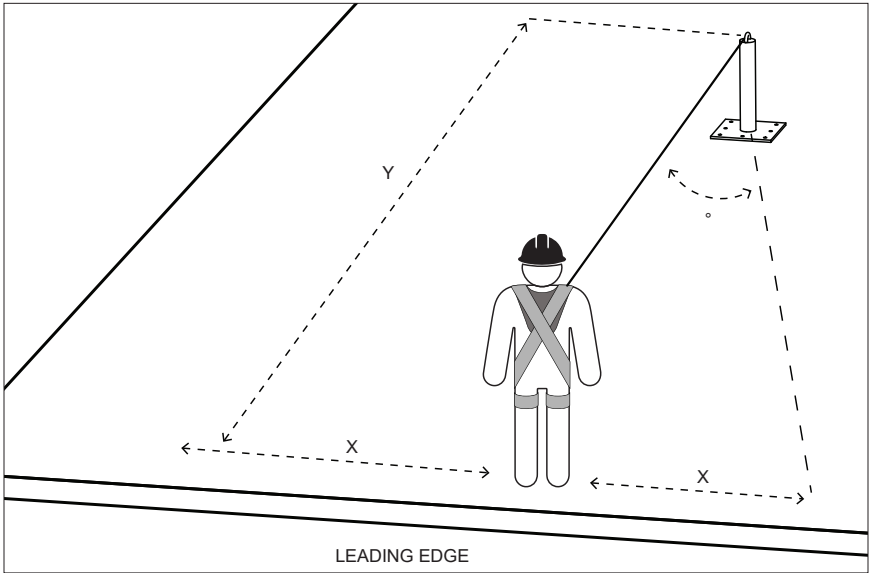

Y

X

°

Anchor Distance from Leading Edge	Working Distance Along Roof Edge (Either Direction)	Working Angle from Perpendicular
6'	8'	53°
10'	9' 9"	45°
15'	11' 7"	38°
20'	13' 3"	33°
25'	14' 6"	30°
30'	16'	28°
35'	17' 2"	26°
40'	18' 3"	24°
45'	19' 4"	23°
50'	19' 10"	21°
55'	21' 4"	21°
60'	22' 3"	21°

► 13.0 INSTALLATION OF POST ANCHOR ON AN ENGINEERED WOOD LOCATION

Prior to the installation of the anchor, a Competent Person must determine that the installation location is capable of supporting intended loads on the anchor. Wooden substrates must have additional support when installing the Post Anchor to ensure necessary strength requirements in the event of a fall.

» Minimum Requirements for Engineered Wood Location:

- The CDX plywood or OSB roof sheathing must be a minimum of 5/8" thick. User must use a 3/4" thick CDX plywood backer and 2" x 6" plywood for support blocks.
- Ensure the substrate is not in a severe state of deterioration. Wet spots, discoloration, excess age, obvious damage, or soft/spongy areas are examples of conditions that may effect the ability of the structure to withstand fall arrest forces.

Fastener Type	Quantity
#14-10 x 3" Grade 8 Hex Head Screw (For Anchor Base Plate)	40
#14 x 3" Screws (11 For Each Truss)	33
#14 x 2" Hex Head Screws (For Wood Deck)	36

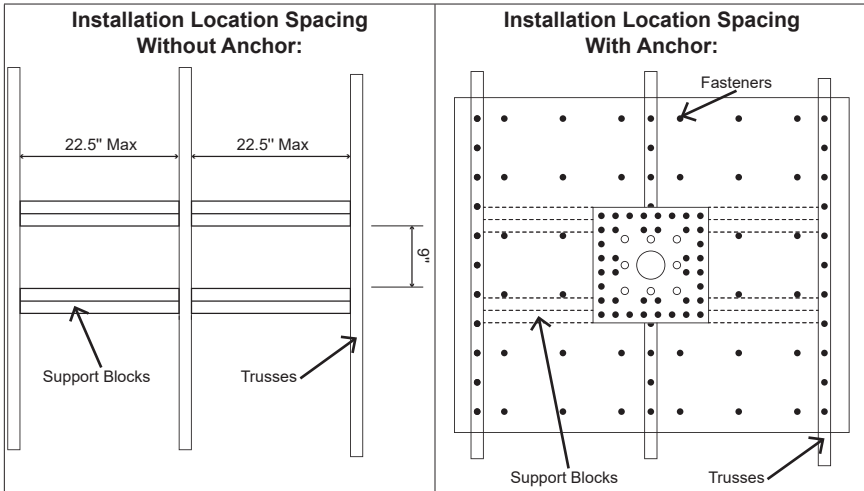

Installation Steps:

1. Measure and cut (4) 2" x 6" support blocks to whatever size is necessary to span to adjacent truss (Fig. 1).
2. Fasten support blocks with (11) #14 x 3" screws on each truss at 4" on center.
3. Measure and cut (2) 3/4" CDX plywood sheets and place onto support blocks (Fig. 2).

4. Measure and cut roof sheathing and place over backer sheets. Sheathing must span over 3 trusses (Fig. 3).
5. Fasten wood deck with (36) #14 x 2" screws at 8" on center.
6. Install the anchor using (40) #14-10 x 3" grade 8 hex head screws (Fig. 4).
7. Ensure all fasteners are fully embedded into wood for proper installation (Fig. 5).

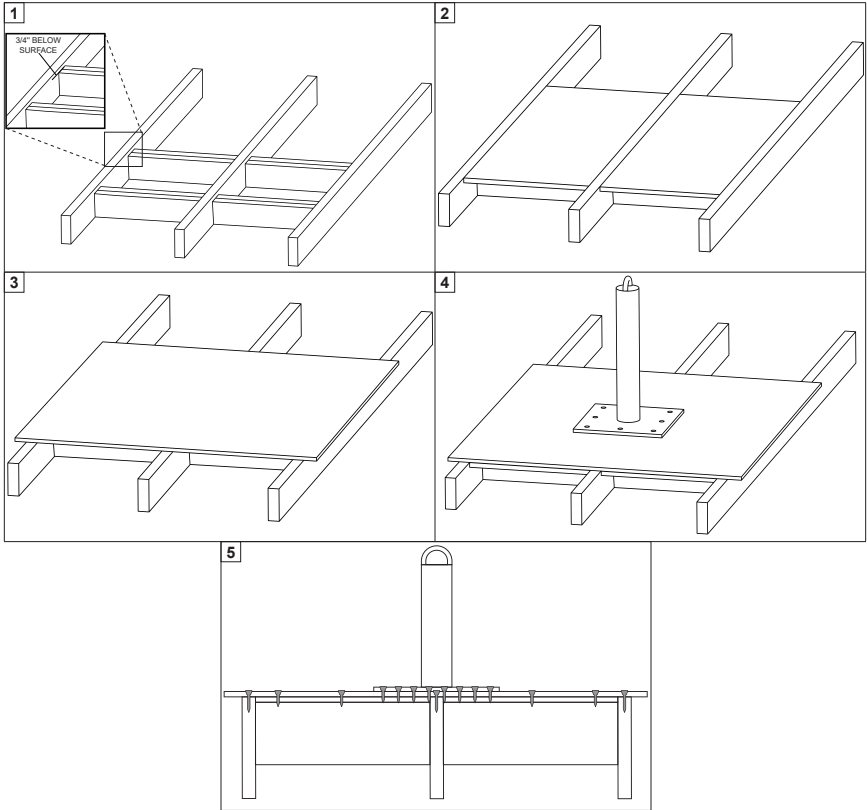

► 14.0 INSTALLATION OF POST ANCHOR ON AN EXISTING WOOD STRUCTURE

Prior to the installation of the anchor, a Competent Person must determine that the installation location is capable of supporting intended loads on the anchor. Wooden substrates must have additional support when installing the Post Anchor to ensure necessary strength requirements in the event of a fall.

» Minimum Requirements for Wood:

- The CDX plywood or OSB roof sheathing must be a minimum of 5/8" thick. User must use a 3/4" thick CDX plywood backer and 2" x 6" plywood for support blocks*.

* **Note:** Support blocks are only necessary for an undermount installation. Support blocks are not needed in a surface-mount installation.

- Ensure the substrate is not in a severe state of deterioration. Wet spots, discoloration, excess age, obvious damage, or soft/spongy areas are examples of conditions that may effect the ability of the structure to withstand fall arrest forces.

UNDERMOUNT INSTALLATION

Fastener Type	Quantity
#14-10 x 3" Grade 8 Hex Head Screw (For Anchor Base Plate)	40
#14 x 3" Screws (11 For Each Truss)	33
#14 x 2" Hex Head Screws (For Backer Board Deck)	36

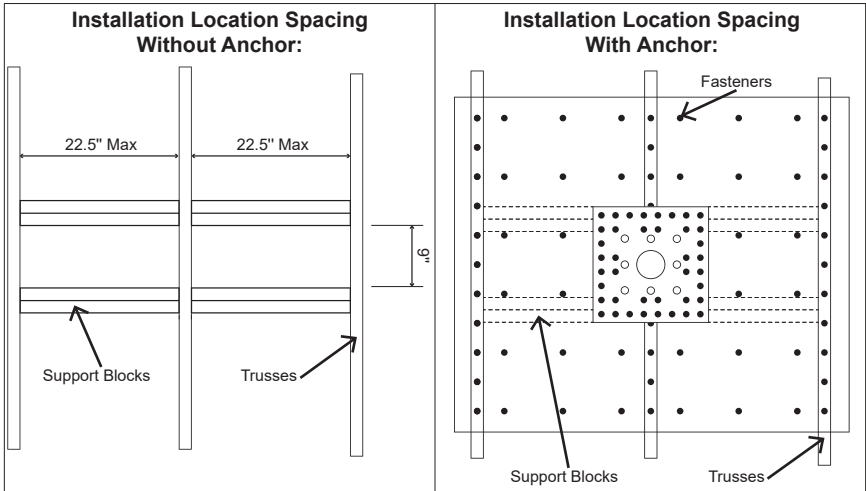

Installation Steps:

1. Find a suitable location on the existing wood structure that allows for the anchor to be centered onto a truss.
2. Measure and cut 3/4" CDX plywood sheets to 48" x 48" (or whatever size is necessary to span to adjacent truss). Fasten to the primary deck using (36) #14 x 2" Hex Head Screws at 8" on center.
3. Measure and cut 2" x 6" support blocks to whatever size is necessary to span to adjacent truss. The support blocks should be installed where the outer edge of the anchor plate will be placed (See Figures Above). Drill pilot holes and fasten support blocks with #14 x 3" screws into trusses.
4. Install the anchor on the primary deck using (40) #14-10 x 3" grade 8 hex head screws (Fig. 3). Make sure anchor is centered on a truss and aligned with the support blocks as described in Step 3.
5. Ensure all fasteners are fully embedded into wood for proper installation (Fig. 4).

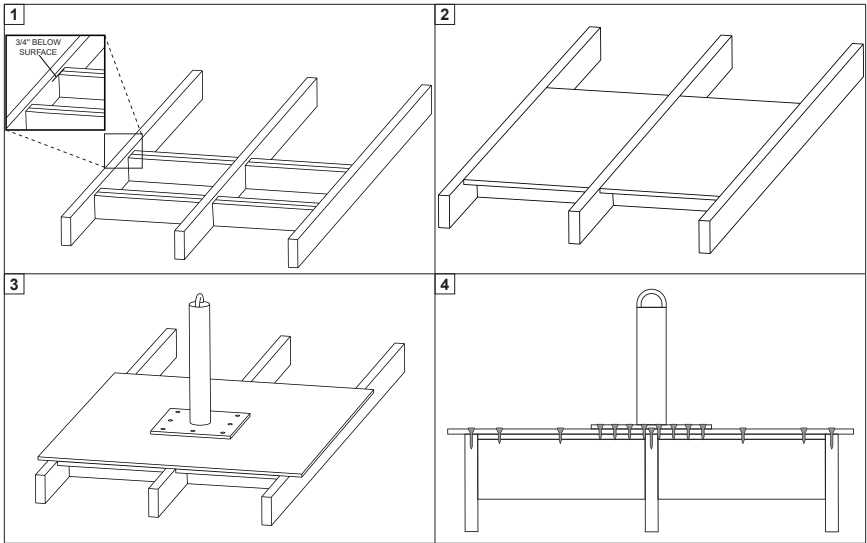

SURFACE-MOUNT INSTALLATION

Fastener Type	Quantity
#14-10 x 3" Grade 8 Hex Head Screw (For Anchor Base Plate)	40
#14 x 3" Screws (11 For Each Truss)	33
#14 x 2" Hex Head Screws (For Backer Board Deck)	36

Installation Steps:

1. Find a suitable location on the existing wood structure that allows for the anchor to be centered onto a truss (Fig. 1).
2. Measure and cut 3/4" CDX backer board to 48" x 48" (or whatever size is necessary to span to adjacent truss). Fasten to the primary deck using (36) #14 x 2" Hex Head Screws at 8" on center (Fig. 2).
3. Drill pilot holes and fasten backer board to the trusses using (33) #14 x 3" Screws at 4" on center. (Fig. 2)
4. Install the anchor on the backer board using (40) #14-10 x 3" grade 8 hex head screws (Fig. 2). Make sure anchor is centered on a truss as described in Step 1.
5. Ensure all fasteners are fully embedded into wood for proper installation (Figs. 3 & 4).

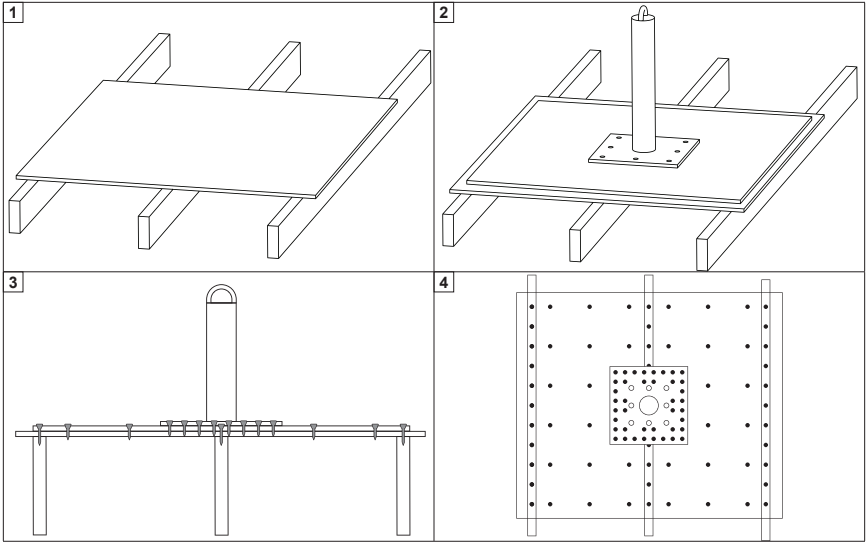

► 15.0 INSTALLATION OF POST ANCHOR ON CONCRETE

Prior to the installation of the anchor, a Competent Person must determine that the installation location is capable of supporting intended loads on the anchor.

» Minimum Requirements for Concrete:

- Must be a minimum of 2,500 PSI and a minimum of 6" thick.
- The concrete must be fully cured prior to installation.
- Ensure the substrate is not in a severe state of deterioration. Severe cracking, excessive rust staining, holes, noticeable deterioration, or excess age of materials are examples of conditions that may effect the ability of the structure to withstand fall arrest forces.

Fastener Type	Quantity
1/2" Hilti HIT-Z Rods (Or Equivalent)	8

Installation Steps:

1. Install the anchor a minimum of 8" away from all edges using (8) 1/2" Hilti HIT-Z Rods. Fasteners must be installed with a minimum embedment of 3-1/2" (Fig. 1)
2. Ensure all fasteners are fully embedded into concrete for proper installation.

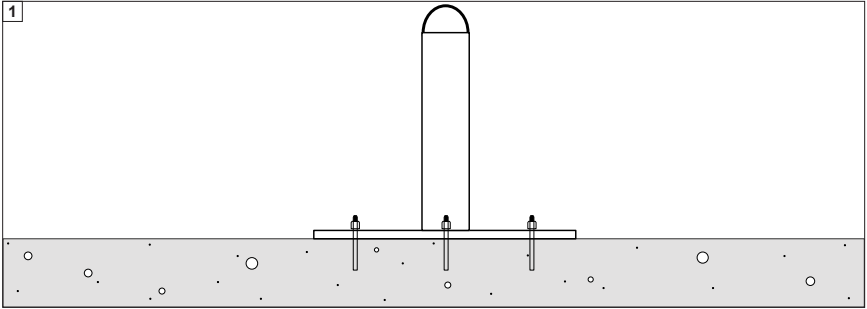

► 16.0 INSTALLATION OF POST ANCHOR ON STEEL

Prior to the installation of the anchor, a Competent Person must determine that the installation location is capable of supporting intended loads on the anchor.

» Minimum Requirements for Steel:

- The steel decking must be a minimum of 20 gauge.
- Ensure the substrate is not in a severe state of deterioration. Excessive rust, heavy oxidation, holes, cracks, severe weather, or excess age of the material are examples of conditions that may effect the ability of the structure to withstand fall arrest forces.

Fastener Type	Quantity
#14-14 x 2" Screws (For Metal Decking)	40

Installation Steps:

1. Install the anchor using (40) #14-14 x 2" Screws. Fasteners must fully penetrate metal decking by at least 1/4" (Fig. 1)
2. Ensure all fasteners are fully embedded into metal decking for proper installation.

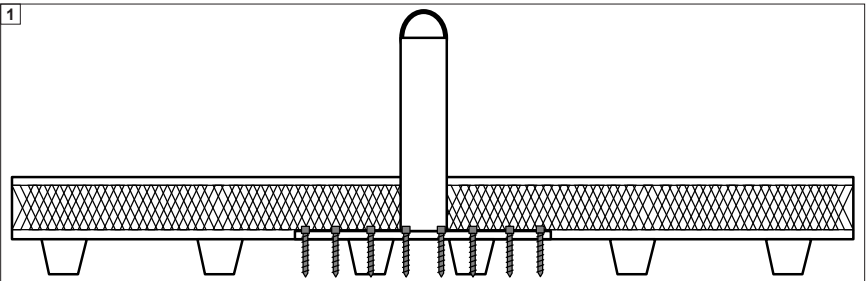

► 17.0 INSPECTION & MAINTENANCE

The user must keep instructions available for reference and record the date of first use on Page 2. The user must immediately remove the anchor from service if defects or damage are found, or if exposed to forces of fall arrest.

Work Area:

- Inspect the work area to ensure the location is free of any damage including, but not limited to, debris, cracking, rot, decay, structural deterioration, rust, and any hazardous materials.
- A Competent Person must determine that the installation location to be utilized will support the intended loads.

Frequency:

- A Competent Person, other than the user, must inspect the Post Anchor at least once annually.
- While conducting inspections, the Competent Person must consider all applications and hazards that the equipment may have been subjected to while in use.
- Competent Person inspections must be recorded in the Inspection Log included in this manual (Page 23), as well as the inspection table labels on each product individually. The Competent Person must place their initials in the block which corresponds with the month and year that the inspection is performed. All individual labels on the equipment will be initialed in the same manner.

Directions:

- Prior to each use, inspect the anchor for possible deficiencies including, but not limited to, missing parts, corrosion, deformation, pits, burrs, rough surfaces, sharp edges, cracking, rust, paint buildup, excessive heating, alteration, and missing or illegible labels. Inspect all components of the anchor (Images 1 & 2).

Repairs:

Only Safewaze, or entities authorized in writing by Safewaze, may make repairs to Safewaze fall protection equipment.

Cleaning:

The anchor can be cleaned with water and mild soap. The user shall remove all dirt, possible corrosives, and contaminants from the system prior to, and after, each use. Never use any type of corrosive substance to clean the system.

Excess water shall be blown out with compressed air. Hardware can be wiped off with a clean, dry cloth. Do not store system if wet or damp. Allow equipment to fully dry before being stored.

Storage:

Prior to installation, store the anchor in a cool, dry area where it will not be exposed to extreme light, extreme heat, excessive moisture, or possibly corrosive chemicals or materials.

Lifespan:

The working life of the anchor is determined by work conditions, care, and inspection provided. So long as the system and all components pass inspection, it may remain in service.

Disposal:

Dispose of the anchor if inspection reveals an unsafe or defective condition. If damaged and unserviceable, the system must be destroyed so as not to allow accidental re-use.

IMAGE 1:

IMAGE 2:

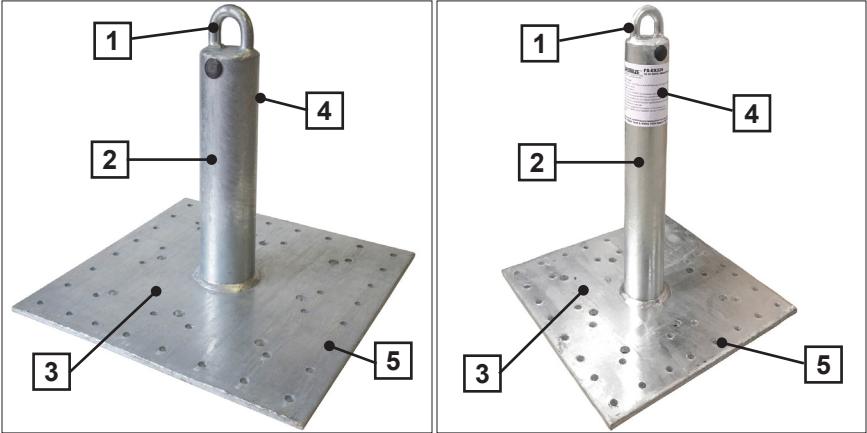

1	Connection Point
2	Anchor Pole
3	Anchor Base
4	Label
5	Fastener Holes

► **18.0 LABEL**



SAFEWAZE

225 Wishire Ave SW, Concord, NC 28025
 (800) 230-0319 | www.safewaze.com

FS-EX325

12 IN DECK ANCHOR for WOOD, CONCRETE, and STEEL

MFG. DATE
 XX/XX

MATERIALS: Galvanized steel

WEIGHT CAPACITY RANGE: 130-310 lbs, or up to 420 lbs if used with equipment explicitly certified for such use.

Maximum 1 connection per anchor.

Only make compatible connections.

Refer to instructions for proper installation and connection methods.

All PFAS equipment must be selected and deemed compatible with this anchor by a Competent Person.

Avoid contact with hazards, including (but not limited to) heat chemicals, electricity, and sharp or abrasive edges and surfaces.

Product lifetime is indefinite, so long as the equipment passes pre-use and Competent Person inspections.

This unit must be inspected prior to each use.

A Competent Person must complete a formal inspection of this unit every 6 mos.

If equipment fails inspection, IMMEDIATELY REMOVE THE UNIT FROM SERVICE.

Do not remove label.

INSPECTION

	J	F	M	A	M	J	J	A	S	O	N	D

Must follow all manufacturer's instructions included with the equipment at the time of shipment. Meets: OSHA 1926.502, 1910.140, 1910.66

0119SR1



Manufacturer: _____
 Model Number: _____
 Description: _____
 Serial Number: _____
 Lot Number: _____
 Date of Manufacture: _____

Company: _____
 Name of Inspector: _____
 Signature: _____
 Date of Inspection: _____
 In-Service Date: _____

Anchor Galvanized Steel Stainless Steel Aluminum
 Material: Zinc-Plated Steel Other: _____

LABELS & MARKINGS

	PASS	FAIL	NOTE
Label (Intact and Legible)			
Appropriate ANSI / OSHA / CSA Markings			
Inspections are Current / Up-to-Date			
Date of First Use			

HARDWARE (If Applicable)

	PASS	FAIL	NOTE
Signs of Deformity			
D-Ring / Connection Points			
Hook Gate / Rivets (if applicable)			
Corrosion / Pitting / Nicks			

ANCHORAGE CONNECTOR

	PASS	FAIL	NOTE
Termination (Stitch, Splice, or Swage)			
Deterioration / Corrosion			
Cuts / Burns / Holes			
Integrity of Welds / Rivets			
Paint Contamination			
Stitching / Wire Condition			
Heat Corrosion / UV Damage			
Separation / Bird-Caging			

CABLE ANCHOR

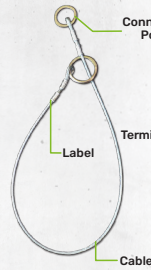

CROSS ARM STRAP

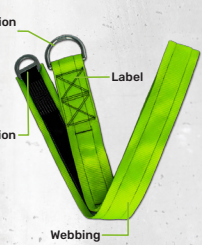

ROOF ANCHOR





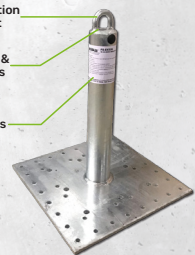































POST ANCHOR



NOTES



Inspection Date:	Inspector:	Pass/Fail:  	Comments/ Corrective Action:
		 	
		 	
		 	
		 	
		 	
		 	
		 	
		 	
		 	
		 	
		 	
		 	
		 	
		 	
		 	
		 	



SAFEWAZE

Address: 225 Wilshire Ave SW, Concord, NC 28025

Phone: (800) 230-0319

Fax: 704-262-9051

Email: info@safewaze.com

Website: safewaze.com