



## 023-12160

### 10' to 20' Belmont Safety Hatch System with Round Brackets

#### FEATURES :

- System mounts directly to ladder for stability
- Ground level operation to open, close and secure hatch
- Safe transitions with built-in extension pole
- Manually operated drive unit with simple crank
- Installs on systems from 10' to 20'
- For use on hatches from 30" square to 36" square
- System Capacity: 600 lbs. (272.2 kg)
- Assembly required, padlock not included
- Includes all required components and fasteners:
  - (6) Brackets for side mounted installation on round tubing 1 3/4" diameter
  - (1) Lifting tube extension
  - (2) Intermediate guide brackets
  - (1) Drill bit rivet adapter

#### ITEM WEIGHT :

- 39.4 lbs. (17.9 kg)



USER WEIGHT CAPACITY	
ANSI	N/A
OSHA	N/A

STANDARD COMPLIANT WITH	
ANSI	N/A
OSHA	N/A

RELATED PRODUCTS	
023-12161	20' to 27' Belmont Safety Hatch System with Round Brackets
023-12162	27' to 34' Belmont Safety Hatch System with Round Brackets
023-12165	Round Backing Plate Set, Belmont Safety Hatch

COMPONENT	MATERIAL SPECIFICATION
System	Powder coated steel
Fasteners	Zinc plated steel



## 023-12161

### 20' to 27' Belmont Safety Hatch System with Round Brackets

#### FEATURES :

- System mounts directly to ladder for stability
- Ground level operation to open, close and secure hatch
- Safe transitions with built-in extension pole
- Manually operated drive unit with simple crank
- Installs on systems from 20' to 27'
- For use on hatches from 30" square to 36" square
- System Capacity: 600 lbs. (272.2 kg)
- Assembly required, padlock not included
- Includes all required components and fasteners:
  - (8) Brackets for side mounted installation on round tubing 1 3/4" diameter
  - (2) Lifting tube extensions
  - (4) Intermediate guide brackets
  - (1) Drill bit rivet adapter

#### ITEM WEIGHT :

- 45.2 lbs. (20.5 kg)



USER WEIGHT CAPACITY	
ANSI	N/A
OSHA	N/A

STANDARD COMPLIANT WITH	
ANSI	N/A
OSHA	N/A

RELATED PRODUCTS	
023-12160	10' to 20' Belmont Safety Hatch System with Round Brackets
023-12162	27' to 34' Belmont Safety Hatch System with Round Brackets
023-12165	Round Backing Plate Set, Belmont Safety Hatch

COMPONENT	MATERIAL SPECIFICATION
System	Powder coated steel
Fasteners	Zinc plated steel



## 023-12162

### 27' to 34' Belmont Safety Hatch System with Round Brackets

#### FEATURES :

- System mounts directly to ladder for stability
- Ground level operation to open, close and secure hatch
- Safe transitions with built-in extension pole
- Manually operated drive unit with simple crank
- Installs on systems from 27' to 34'
- For use on hatches from 30" square to 36" square
- System Capacity: 600 lbs. (272.2 kg)
- Assembly required, padlock not included
- Includes all required components and fasteners:
  - (10) Brackets for side mounted installation on round tubing 1 3/4" diameter
  - (3) Lifting tube extensions
  - (6) Intermediate guide brackets
  - (1) Drill bit rivet adapter

#### ITEM WEIGHT :

- 51.1 lbs. (23.2 kg)

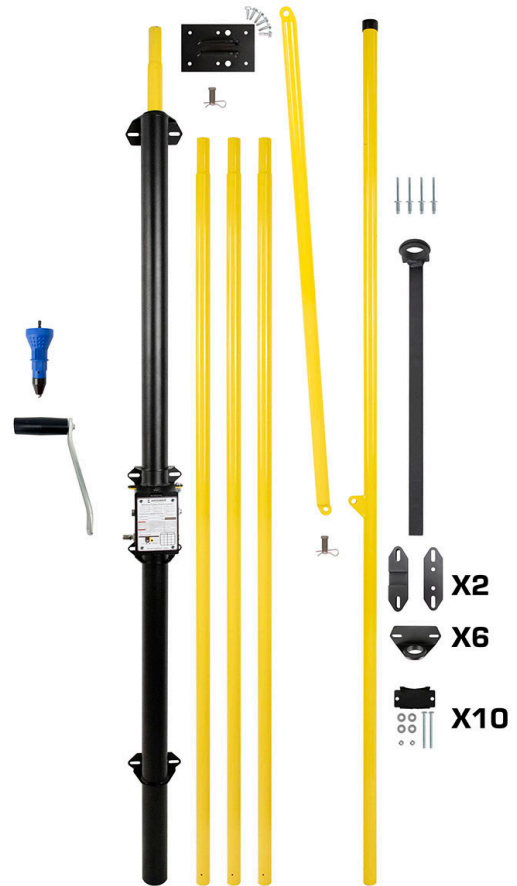

USER WEIGHT CAPACITY	
ANSI	N/A
OSHA	N/A

STANDARD COMPLIANT WITH	
ANSI	N/A
OSHA	N/A

RELATED PRODUCTS	
023-12160	10' to 20' Belmont Safety Hatch System with Round Brackets
023-12161	20' to 27' Belmont Safety Hatch System with Round Brackets
023-12165	Round Backing Plate Set, Belmont Safety Hatch

COMPONENT	MATERIAL SPECIFICATION
System	Powder coated steel
Fasteners	Zinc plated steel