

# 18" Anchor Post for Wood, Steel, & Concrete

## FS-EX326 18" Anchor Post

This 18" fixed anchor post offers the versatility to be used to create a secure anchor point on wood, steel or concrete structures. This single person anchor post can also be used with horizontal lifelines.

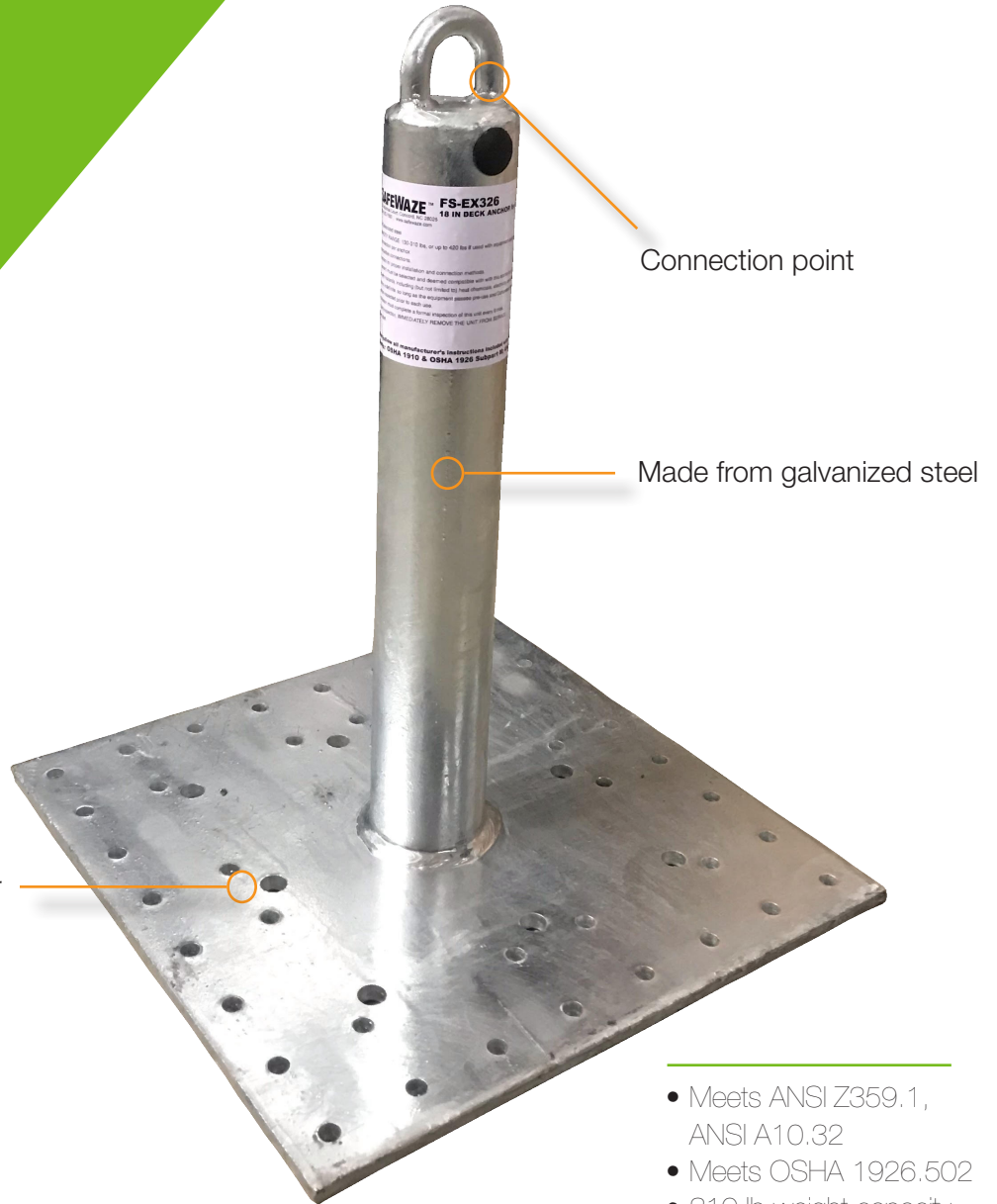



[safewaze.com](http://safewaze.com) | (P) 704-262-7893 | (F) 704-262-9051  
322 Industrial Court, Concord, NC 28025

## TECHNICAL DATA SHEET

### FS-EX326

18" Anchor Point Post  
(For Wood, Steel, and Concrete)

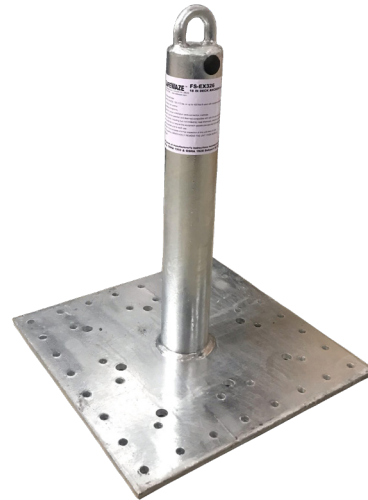

<b>Description</b>	Safewaze™ FS-EX326 18" Anchor Point Post is easy to install. Any attachment material must be rated to meet OSHA, federal, state, and local government regulations for fall protection anchor points.
<b>Dimensions</b>	16 in X 16 in (406.4 mm x 406.4 mm) Baseplate 20" (508 mm) Overall height from bottom of baseplate to top of loop
<b>Number of Holes in Base</b>	(40) - Fasten with #14-10 2" wood screws (Not Included). Screws must extend through deck 3/4" minimum  (40) - Fasten with #14-14 2" screws for metal decking (Not Included). Screws must penetrate metal decking by at least 1/4"  (8) - Fasten with 1/2" Hilit HIT-Z Rods or equivalent (Not Included). Minimum 3-1/2" embedment required
<b>Deck Requirements</b>	Minimum 5/8" CDX Plywood. All screw holes must be used.  Minimum 20 gauge steel material for steel installation. All screw holes must be used.  Minimum 6" thick, 2,500 p.s.i., concrete for concrete installation. All concrete fastener installation holes must be used.
<b>Material</b>	Galvanized Steel
<b>Working Load</b>	310 lbs (140.61 kg) - Designed for single person use
<b>Strength</b>	5,000 lbs (2267.96 kg) Ultimate Strength. Supporting structure must have a strength of at least 5,000 lbs (2267.96 kg)
<b>Weight</b>	36 lbs (16.33 kg)
<b>Applicable Standards</b>	Meets OSHA 1926.502 - ANSI Z359.1 - ANSI A10.32

\*Anchorages used for attachment of personal fall arrest equipment shall be independent of any anchorage being used to support or suspend platforms and be capable of supporting at least 5,000 (22.2kN) pounds per employee attached.



## FS-EX325 / FS-EX326 Anchor Post Instruction Manual



### **WARNING**

This product is part of a personal fall arrest, work positioning, fall restraint, or rescue system. The manufacturer's instructions must be provided to users of this equipment. The user must follow the manufacturer's instructions for each component of the system. The user must read and understand these instructions before using this equipment. Manufacturer's instructions must be followed for proper use and maintenance of this equipment. Alterations to this product, misuse of this product, or failure to follow instructions may result in serious injury or death.

### **IMPORTANT**

Questions regarding the use, care, or suitability of this equipment for your application? Contact SAFEWAZE™.

### **IMPORTANT**

Record initial usage of product on Page 2, and Page 10. Competent Person inspections are required to be documented in the Inspection Log Table on Page 10.

## TABLE OF CONTENTS

1	INTRODUCTION .....	3
2	APPLICABLE SAFETY STANDARDS .....	3
3	WORKER CLASSIFICATIONS .....	3
4	LIMITATIONS .....	4
5	COMPATIBILITY OF CONNECTORS .....	5
6	MAKING CONNECTIONS .....	6
7	COMPONENTS AND SPECIFICATIONS .....	7
8	PRODUCT APPLICATIONS .....	7
9	INSTALLATION AND USE .....	8-9
10	INSPECTION .....	9-10
11	SAFETY INFORMATION .....	10
12	LABELS .....	11

### User Information

Date of First Use: \_\_\_\_\_

Serial#: \_\_\_\_\_

Trainer: \_\_\_\_\_

User: \_\_\_\_\_

**Do not throw away these instructions!**

**Read and understand these instructions before using equipment!**

## INTRODUCTION

Thank you for purchasing the SAFEWAZE™ FS-EX325 / FS-EX326. This manual must be read and understood in its entirety, and used as part of an employee training program as required by OSHA or any applicable state agency.

This manual and any other instructional material must be available to the user of the equipment. The user must understand how to safely and effectively use the FS-EX325 / FS-EX326, and all fall protection equipment used in conjunction with the FS-EX325 / FS-EX326.

## APPLICABLE SAFETY STANDARDS

When used according to instructions, this product meets or exceeds all applicable OSHA 1926 Subpart M, OSHA 1910, ANSI Z359.1-2007, and ANSI A10.32-2012 standards for fall protection. Applicable standards and regulations depend on the type of work being done, and also might include state-specific regulations. Refer to local, state, and federal (OSHA) requirements for additional information concerning the governing of occupational safety regarding Personal Fall Arrest Systems (PFAS).

## Worker Classifications



Understand the definitions of those who work in proximity of or may be exposed to fall hazards.

**Qualified Person:** A person with an accredited degree or certification, and with extensive experience or sufficient professional standing, who is considered proficient in planning and reviewing the conformity of fall protection and rescue systems.

**Competent Person:** A highly trained and experienced person who is **assigned by the employer** to be responsible for all elements of a fall safety program, including, but not limited to, its regulation, management, and application. A person who is proficient in identifying existing and predictable hazards, and who has the authority to stop work in order to eliminate hazards.

**Authorized Person:** A person who is assigned by their employer to work around or be subject to potential or existing fall hazards.

**It is the responsibility of a Qualified or Competent Person to supervise the job site and ensure safety regulations are complied with.**

## Limitations

**Fall Clearance:** There must be sufficient clearance below the anchorage connector to arrest a fall before the user strikes the ground or an obstruction. When calculating fall clearance, account for a MINIMUM 2' safety factor, deceleration distance, user height, length of lanyard/SRL, and all other applicable factors. (See Figure 1)

**FIGURE 1**

**For all applications: worker weight capacity range  
(including all clothing, tools, and equipment) is 130-310 lbs**

### Fall Clearance Diagram

\*\*\*Diagram shown is an example  
fall clearance calculation ONLY.

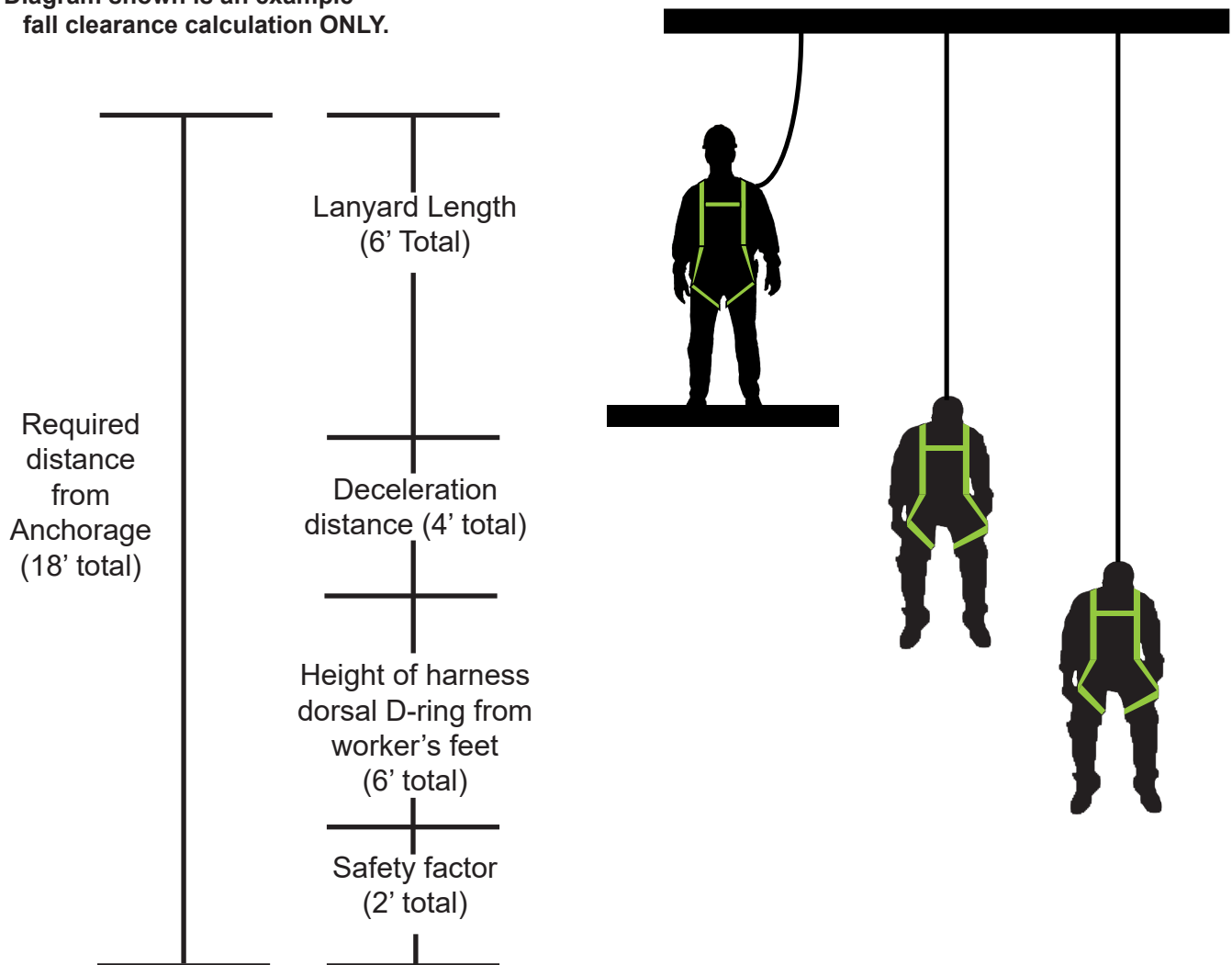

**Swing Falls:** Prior to installation or use, make considerations for eliminating or minimizing all swing fall hazards. Swing falls occur when the anchor is not directly above the location where a fall occurs. Always work as close to in line with the anchor point as possible. Swing falls significantly increase the likelihood of serious injury or death in the even of a fall. (See Figure 2)

**FIGURE 2**

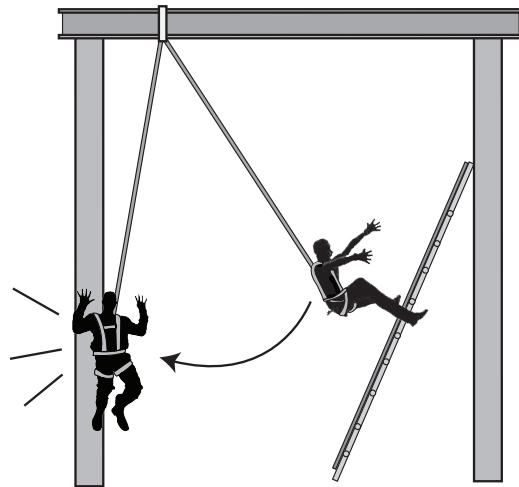

**COMPATIBILITY OF CONNECTORS**

Connectors are compatible with connecting elements when they have been designed to work together in such a way that their sizes and shapes do not cause their gate mechanisms to inadvertently open regardless of how they become oriented. Connectors (hooks, carabiners, and D-rings) must be capable of supporting at least 5,000 lbs. (22.2 kN). Connectors must be compatible with the anchorage or other system components (see Figure 4). Do not use equipment that is not compatible. Non-compatible connectors may unintentionally disengage (see Figure 3). Connectors must be compatible in size, shape, and strength. Self-locking snap hooks and carabiners are required by ANSI Z359 and OSHA guidelines. Contact SAFEWAZE™ if you have any questions about compatibility.



**NOTE:** SOME SPECIALTY CONNECTORS HAVE ADDITIONAL REQUIREMENTS. CONTACT SAFEWAZE™ WITH QUESTIONS.

**FIGURE 3 - UNINTENTIONAL DISENGAGEMENT**

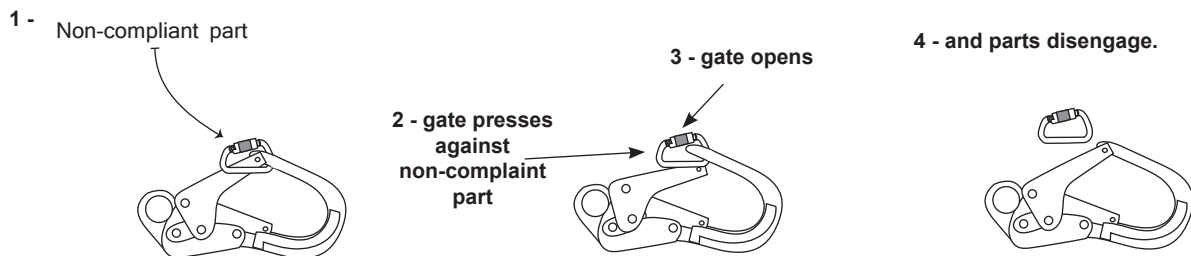

Using a connector that is undersized or irregular in shape (1) to connect a snap hook or carabiner could allow the connector to force open the gate of the snap hook or carabiner. When force is applied, the gate of the hook or carabiner presses against the non-compliant part (2) and forces open the gate (3). This allows the snap hook or carabiner to disengage (4) from the connection point.

## MAKING CONNECTIONS

Snap hooks and carabiners used with this equipment must be double locking and/or twist lock. Ensure all connections are compatible in size, shape and strength. Do not use equipment that is not compatible. Ensure all connectors are fully closed and locked.

SAFEWAZE™ connectors (snap hooks and carabiners) are designed to be used only as specified in each product's user's instructions. See figure 4 for examples of inappropriate connections. Do not connect snap hooks and carabiners:

- To a D-ring to which another connector is attached.
- In a manner that would result in a load on the gate (with the exception of tie back hooks).
- NOTE: Large snap hooks must not be connected to objects which will result in a load on the gate if the hook twists or rotates, unless the snap hook complies with ANSI Z359.1-2007 or ANSI Z359.12 and is equipped with a 3,600 lb (16 kN) gate. Check the marking on your snap hook to verify its compatibility.



**NOTE:** Large throat snap hooks must not be connected to standard size D-rings or similar objects which will result in a load on the gate if the hook or D-ring twists or rotates, unless the snap hook complies with ANSI Z359.1-2007 or ANSI Z359.12 and is equipped with a 3,600 lb (16 kN) gate. Check the marking on your snap hook to verify that it is appropriate for your application.

- In a false engagement, where features that protrude from the snap hook or carabiner catch on the anchor, and without visual confirmation seems to be fully engaged to the anchor point.
- To each other.
- By wrapping the web lifeline around an anchor and securing to lifeline except as allowed for Tie Back models.
- To any object which is shaped or sized in a way that the snap hook or carabiner will not close and lock, or that roll-out could occur.
- In a manner that does not allow the connector to align properly while under load.

**FIGURE 4 - INAPPROPRIATE CONNECTIONS**

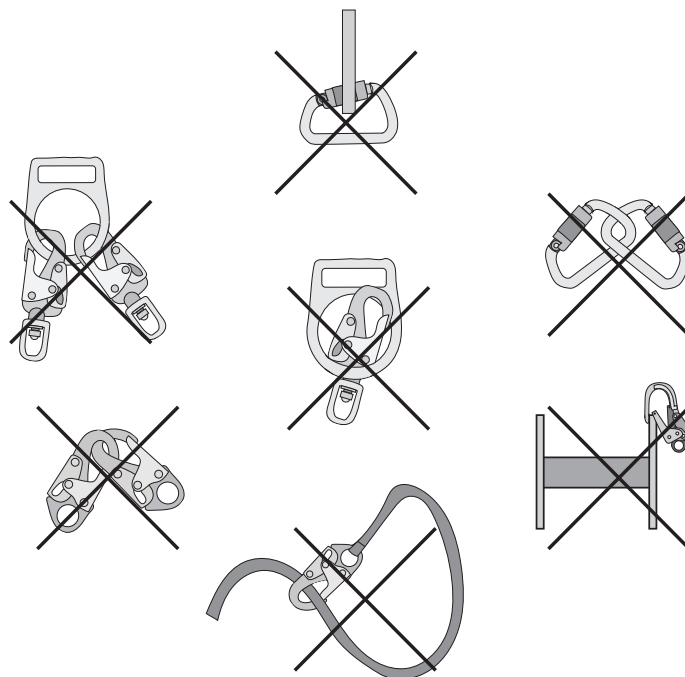



## Components and Specifications

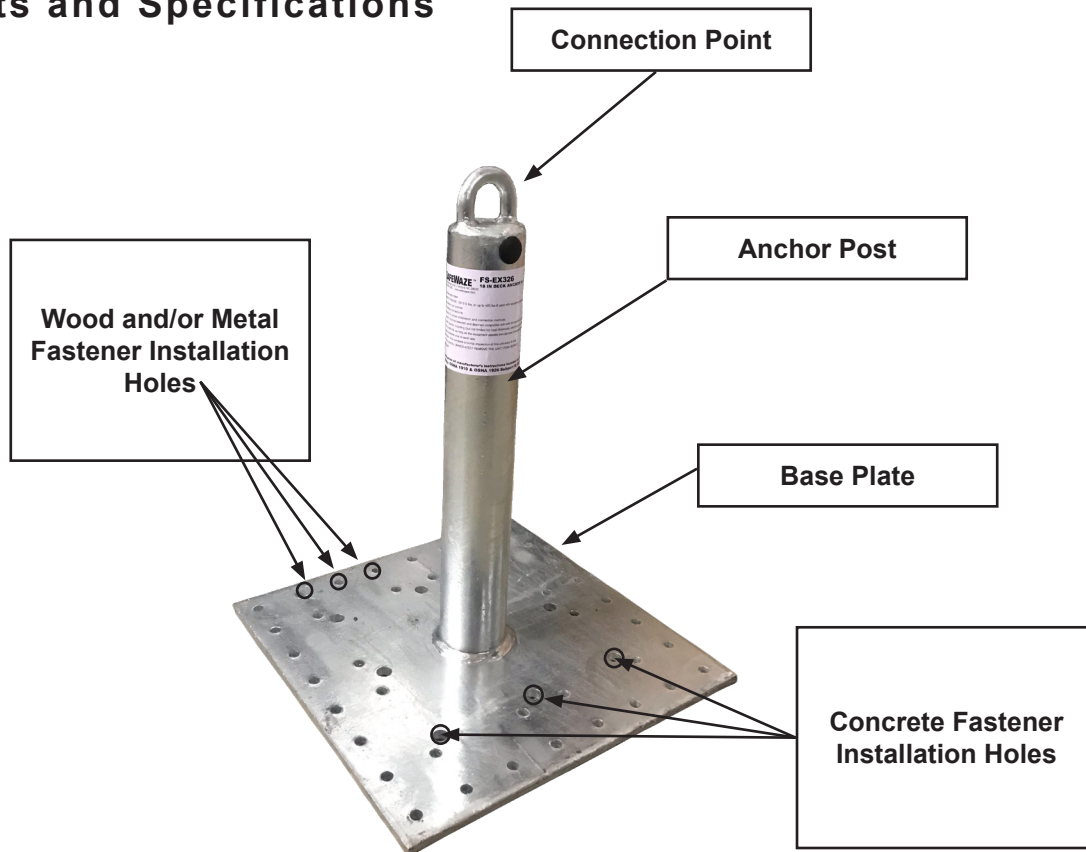

## Product Applications

FS-EX325 / FS-EX326 Anchor Post's can be used as a component of a Personal Fall Arrest System (PFAS), as a component in Fall Restraint applications, for Work Positioning, and as a component in Rescue / Confined Space applications.

**For Personal Fall Arrest** applications, the FS-EX325 / FS-EX326 may be used to support a MAXIMUM of 1 Personal Fall Arrest System. The structure to which the FS-EX325 / FS-EX326 is attached must withstand loads applied in the directions permitted by the system of at least 5,000 lbs., or achieve a minimum 2:1 safety factor as determined by a Qualified Person. Maximum allowable free fall is 6', or up to 12' if used in conjunction with equipment specifically certified for such use.

**For Fall Restraint** the FS-EX325 / FS-EX326 may be use in systems to prevent workers from reaching the leading edge or edge of a fall hazard. If used in Fall Restraint applications, the user must always account for fully deployed length of lanyard or SRL. The structure to which the FS-EX325 / FS-EX326 is attached must withstand loads of at least 1,000 lbs. No free fall is allowed.

**For Work Positioning** applications the FS-EX325 / FS-EX326 allows a worker to to be supported and work freely with both hands. The structure to which the FS-EX325 is attached must withstand loads applied in the directions permitted by the system of at least 3,000 lbs. Maximum allowable free fall is 2'.

**For Rescue / Confined Space** applications, the FS-EX325 / FS-EX326 can function as a component of a system to effectively and safely recover a worker from a confined space location or after exposure to a fall. Configurations of rescue systems can vary depending on the type of rescue required. The structure to which the FS-EX325 / FS-EX326 is attached must withstand loads applied in the directions permitted by the system of at least 3,000 lbs. No free fall is allowed.

# Installation and Use

## Wood Installation

Minimum Substrate for Wood Installation is 5/8" CDX

Wood Installation requires (40) #14-10 2" screws for wood decking

To install, place FS-EX325 / FS-EX26 Anchor Post in desired installation location, and install ALL fasteners until snug to wood decking (ALL wood fastener installation holes MUST be used). User must ensure that ALL fasteners are fully embedded into wood decking.

### Wood Installation Example Diagram

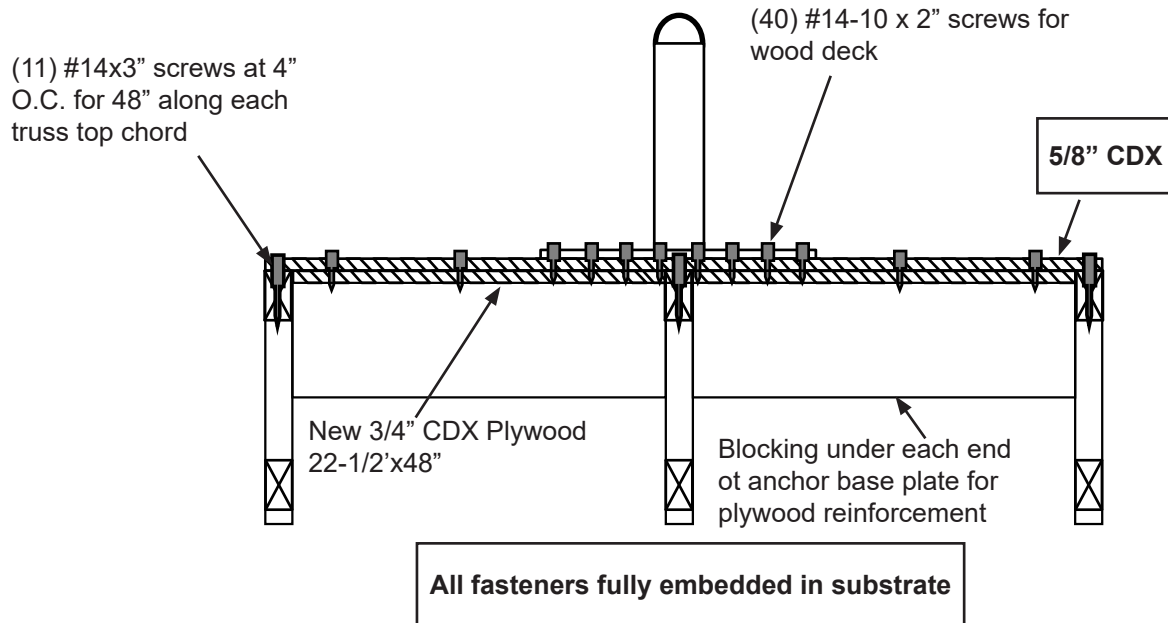
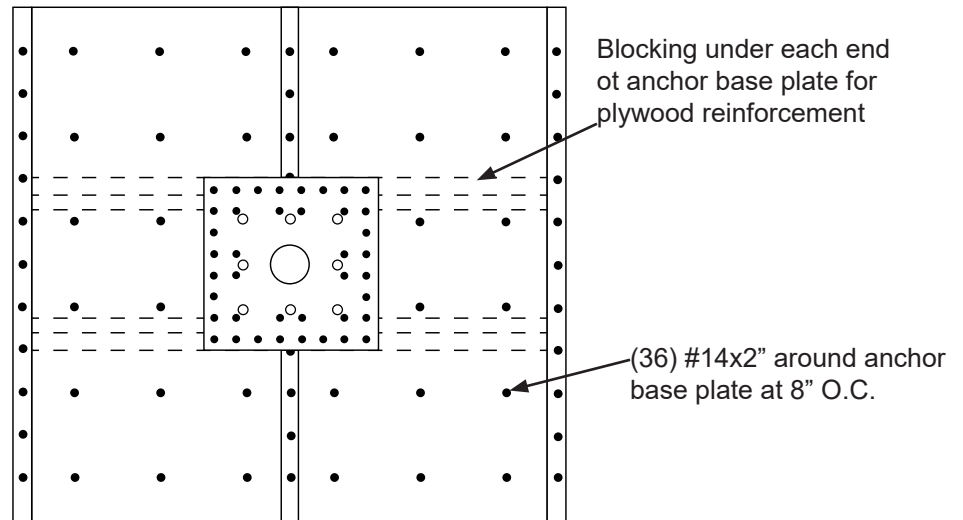

## Metal Installation

Minimum Substrate for Metal Installation is 20 gauge material

Metal Installation requires (40) #14-14 2" screws for metal decking

To install, place FS-EX325 / FS-EX326 Anchor Post in desired installation location, and install ALL fasteners until snug to metal decking (ALL metal fastener installation holes MUST be used). User must ensure that ALL fasteners penetrate metal decking by at least 1/4".

### Metal Installation Example Diagram

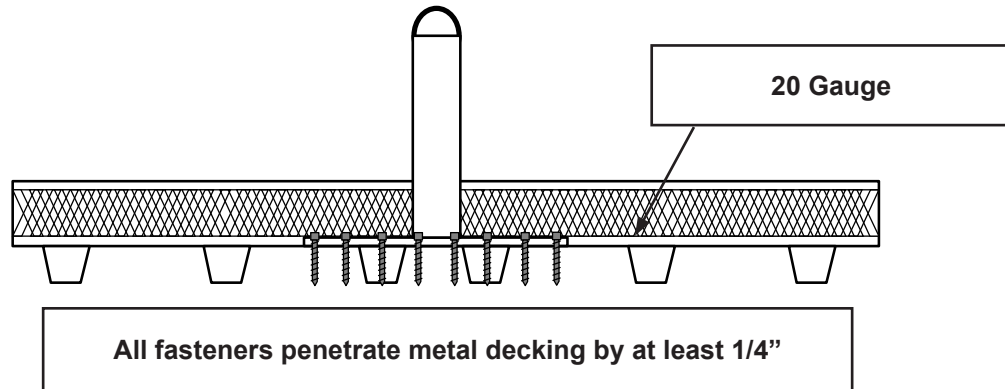

### Concrete Installation

Minimum Substrate for Concrete Installation is 6" thick, 2,500 p.s.i.

Concrete Installation requires (8) 1/2" Hilti HIT-Z Rods or equivalent, with minimum 3-1/2" embedment

To install, place FS-EX325 / FS-EX326 Anchor Post in desired installation location. Installation site must be a minimum 8" from all edges. Install ALL fasteners until snug and ensure FS-EX325 is fully secured to concrete substrate. (ALL concrete fastener installation holes MUST be used). User must ensure that ALL fasteners are fully embedded into concrete substrate. User should always refer to fastener manufacturer's instructions regarding fastener installation.

### Concrete Installation Example Diagram

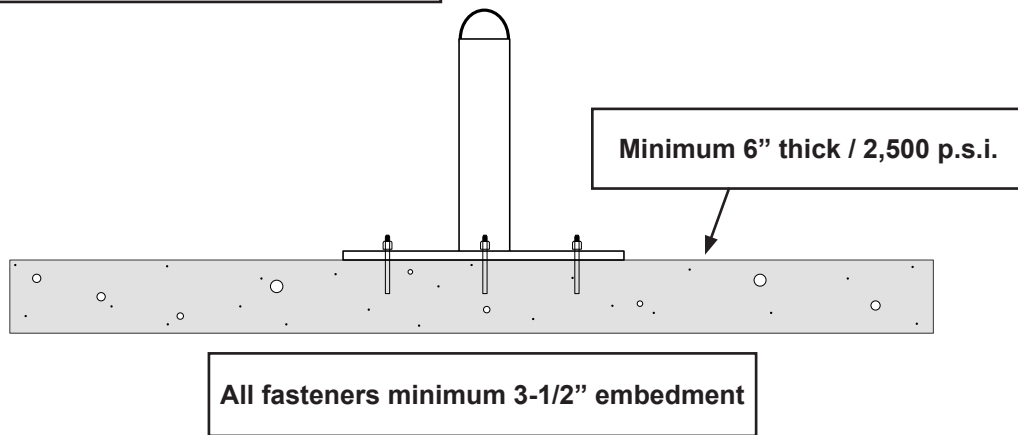

## Inspection

User must inspect the FS-EX325 / FS-EX326 prior to each use for damage or deficiencies, including, but not limited to, cracking, rust, corrosion, deformation, alteration, sharp edges, damage due to excessive heat, and missing or illegible labels.

Ensure that work area for intended installation of the FS-EX325 / FS-EX326 is free from damage or conditions that would make the area unsuitable for installation. The user must ensure that the structure to which the FS-EX325 / FS-EX326 is intended to be fastened to will support the application specific loads covered in this manual.

A Competent Person other than the user must inspect the FS-EX325 / FS-EX326 at least every 6 months. These Competent Person inspections must be recorded in the Inspection Log included in this manual and in the Inspection Table included on the product label.

While conducting inspections, the Competent Person must consider all applications and hazards that the equipment may have been subjected to while in use.

# Inspection Log

Date of First Use: \_\_\_\_\_

Product lifetime is indefinite as long as it passes pre-use and Competent Person inspections. User must inspect prior to each use. Competent Person other than the user must complete formal inspection at least annually. Competent person to inspect and initial table below:

	JAN	FEB	MAR	APR	MAY	JUN	JUL	AUG	SEP	OCT	NOV	DEC

**If equipment fails inspection  
IMMEDIATELY REMOVE FROM SERVICE**

## Safety Information



### WARNING

Failure to understand and comply with safety regulations may result in serious injury or death. Regulations included herein are not all-inclusive, are for reference only, and are not intended to replace a Competent Person's judgement or knowledge of federal or state standards.

Do not alter equipment. Do not misuse equipment.

Workplace conditions, including, but not limited to, flame, corrosive chemicals, electrical shock, sharp objects, machinery, abrasive substances, weather conditions, and uneven surfaces, must be assessed by a Competent Person before fall protection equipment is selected.

The inspection of the workplace must anticipate where workers will be performing their duties, the routes they will take to reach their work, and the potential and existing fall hazards they may be exposed to. Fall protection equipment must be chosen by a Competent Person. Selections must account for all potential hazardous workplace conditions. All fall protection equipment should be purchased in new and unused condition.

Fall protection systems must be selected and installed under the supervision of a Competent Person, and used in a compliant manner. Fall protection systems must be designed in a manner compliant with all federal, state, and safety regulations. Forces applied to anchors must be calculated by a Competent Person.

Unless explicitly stated otherwise, the maximum allowable free fall distance for lanyards must not exceed 6'. Class A SRLs must arrest falls within 24"; Class B SRLs must arrest falls within 54".

Harnesses and connectors selected must be compliant with manufacturer's instructions, and must be of compatible size and configuration. Snap hooks, carabiners, and other connectors must be selected and applied in a compatible fashion. All risk of disengagement must be eliminated. All snap hooks and carabiners must be self-locking and self-closing, and must never be connected to each other.

A pre-planned rescue procedure is required in the event a fall occurs. The rescue plan must be project-specific. The rescue plan must allow for employees to rescue themselves, or provide an alternative means for their prompt rescue. Store rescue equipment in an easily accessible and clearly marked area.

Training of Authorized Persons to correctly erect, inspect, disassemble, maintain, store, and use equipment must be provided by a Competent Person. Training must include the ability to recognize fall hazards, minimize the likelihood of fall hazards, and the correct use of personal fall arrest systems.

NEVER use fall protection equipment of any kind to hang, lift, support, or hoist tools or equipment, unless explicitly certified for such use.

Equipment subjected to forces of fall arrest must immediately be removed from use.

Age, fitness, and health conditions can seriously affect the worker should a fall occur. Consult a doctor if there is any reason to doubt a user's ability to withstand and safely absorb fall arrest forces or perform set-up of equipment. Pregnant women and minors must not use this equipment.

Physical harm may still occur even if fall safety equipment functions correctly. Sustained post-fall suspension may result in serious injury or death. Use trauma relief straps to reduce the effects of suspension trauma.

## Labels



**SAFEWAZE™ FS-EX325**  
**12 IN DECK ANCHOR for WOOD, CONCRETE, and STEEL**

322 Industrial Court, Concord, NC 28025  
 (704) 262-7893 | www.safewaze.com

**MFG. DATE**  
XX/XX

**MATERIALS:** Galvanized steel  
**WEIGHT CAPACITY RANGE:** 130-310 lbs, or up to 420 lbs if used with equipment explicitly certified for such use.  
 Maximum 1 connection per anchor.  
 Only make compatible connections.  
 Refer to instructions for proper installation and connection methods.  
 All PFAS equipment must be selected and deemed compatible with this anchor by a Competent Person.  
 Avoid contact with hazards, including (but not limited to) heat chemicals, electricity, and sharp or abrasive edges and surfaces.  
 Product lifetime is indefinite, so long as the equipment passes pre-use and Competent Person inspections.  
 This unit must be inspected prior to each use.  
 A Competent Person must complete a formal inspection of this unit every 6 mos.  
 If equipment fails inspection, IMMEDIATELY REMOVE THE UNIT FROM SERVICE.  
 Do not remove label.

INSPECTION											
I	J	K	L	M	N	O	P	Q	R	S	T

**Must follow all manufacturer's instructions included with the equipment at the time of shipment.**  
**Meets: OSHA 1910 & OSHA 1926 Subpart M; ANZI Z359.1 & ANSI A10.32**

01581



**SAFEWAZE™ FS-EX326**  
**18 IN DECK ANCHOR for WOOD, CONCRETE, and STEEL**

322 Industrial Court, Concord, NC 28025  
 (704) 262-7893 | www.safewaze.com

**MFG. DATE**  
XX/XX

**MATERIALS:** Galvanized steel  
**WEIGHT CAPACITY RANGE:** 130-310 lbs, or up to 420 lbs if used with equipment explicitly certified for such use.  
 Maximum 1 connection per anchor.  
 Only make compatible connections.  
 Refer to instructions for proper installation and connection methods.  
 All PFAS equipment must be selected and deemed compatible with this anchor by a Competent Person.  
 Avoid contact with hazards, including (but not limited to) heat chemicals, electricity, and sharp or abrasive edges and surfaces.  
 Product lifetime is indefinite, so long as the equipment passes pre-use and Competent Person inspections.  
 This unit must be inspected prior to each use.  
 A Competent Person must complete a formal inspection of this unit every 6 mos.  
 If equipment fails inspection, IMMEDIATELY REMOVE THE UNIT FROM SERVICE.  
 Do not remove label.

INSPECTION											
I	J	K	L	M	N	O	P	Q	R	S	T

**Must follow all manufacturer's instructions included with the equipment at the time of shipment.**  
**Meets: OSHA 1910 & OSHA 1926 Subpart M; ANZI Z359.1 & ANSI A10.32**

01592



SAFEWAZE™  
322 Industrail Court  
Concord, NC 28025

PHONE: 1-704-262-7893  
FAX: 1-704-262-9051  
EMAIL: [info@safewaze.com](mailto:info@safewaze.com)

Web: [safewaze.com](http://safewaze.com)